

**MESSUHR, 10 MM**

*DIAL INDICATOR, 10 MM*

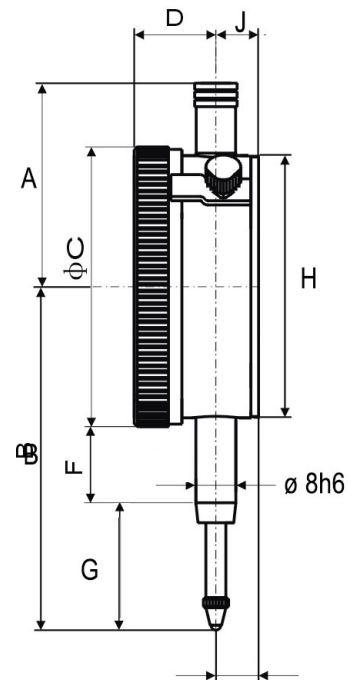

- Genauigkeit nach Werksnorm
- Metallgehäuse
- mit Toleranzmarken
- Aufnahme  $\varnothing$  8 h6
- Ziffernblatt durch Außenring drehbar

- *accuracy according to manufacture standard*
- *metal casing*
- *with tolerance marks*
- *shank  $\varnothing$  8 h6*
- *dial face rotatable by outer ring*



Art.-Nr. <i>Item no.</i>	Messbereich <i>Range mm</i>	Ablesung <i>Reading mm</i>	Genauigkeit <i>Accuracy <math>\mu</math>m</i>	Außenring <i>Dial diameter mm</i>	A+B <i>mm</i>	F <i>mm</i>	G <i>mm</i>	H <i>mm</i>
<b>208.005</b>	10	0,01	17	56	110	20	21	52